



3COM

Quick Start Guide

AP2750 Managed Access Point

3CRWX275075A

The 3Com AP2750 Managed Access Point provides IEEE 802.11a or 802.11b/g wireless access to the network. The access point is designed for use with a 3Com Wireless LAN Switch, and requires hardware installation only. All configuration for the access point takes place on the 3Com Wireless LAN Switch.

You must have a wireless switch device to operate the access point. Two WLAN switch devices can be connected to the access point:

- 3Com WX4400
- 3Com WX1200

Power can be supplied via Power Over Ethernet (PoE) or by an external power supply. Four 3Com PoE devices supply power to the access point:

- 3Com PoE Injector
- 3Com 4400PWR PoE Switch
- 3Com Multi-port PoE power supply
- 3Com WX1200

About This Guide

This Quick Start Guide describes the basic installation of the access point. It covers the following topics:

- 3Com AP2750 Managed Access Point Features
- Observing Safety Precautions
- Step 1: Unpacking the Access Point
- Step 2: Preparing for Installation
- Step 3: Attaching the Antennas
- Step 4: Mounting the Access Point
- Step 5: Connecting the Access Point to a Switch
- Step 6: Checking the LED Indicators
- Troubleshooting

3Com AP2750 Managed Access Point Features

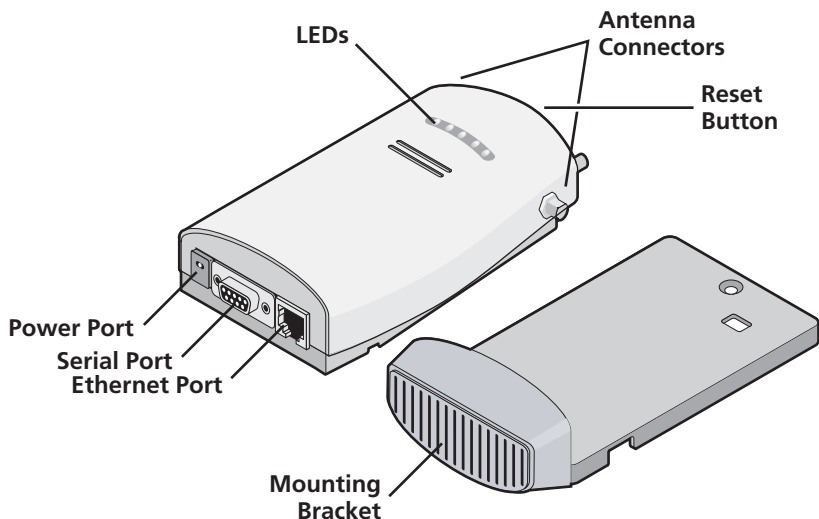

| Feature | Description |
|--------------------|--|
| Power Port | The access point can be powered either via Power Over Ethernet (PoE), or by an external power supply (not included) that is plugged into the Power Port. |
| Serial Port | The serial port is not supported. |
| Ethernet Port | The Ethernet port provides a 10/100BASE-TX Ethernet connection to a 3Com Wireless LAN switch. The connection can be direct to a 3Com switch or indirect through an intermediate Layer 2 or Layer 3 network. Use a standard Category 5 cable with straight-through signaling and standard RJ-45 connectors to connect the access point to the switch on the network. |
| LEDs | The LEDs indicate power and activity. See "Checking the LED Indicators" on page 8 for details. |
| Antenna Connectors | Two SMA-female antenna connectors allow you to connect antennas that operate in 2.4 GHz and 5.3 GHz bands. |
| Reset Button | The reset button is accessible from the back of the access point as well as through the mounting bracket. Push the reset button to restore the access point to its factory default settings. |
| Mounting Bracket | The mounting bracket comes attached to the access point. This mounting bracket allows the access point to be mounted to a wall or ceiling. |

Observing Safety Precautions

This equipment must be installed in compliance with local and national building codes, regulatory restrictions, and FCC rules. For the safety of people and equipment, only professional network personnel should install the access point.



WARNING: To comply with FCC radio frequency (RF) exposure limits, a minimum body-to-antenna distance of 20 cm (8 in.) must be maintained when the access point is operational.



WARNING: To avoid possible injury or damage to equipment, you must use power supply equipment that is safety certified according to UL, CSA, IEC, or other applicable national or international safety requirements for the country of use. All references to power supply in this document refer to equipment meeting these requirements.

1 Unpacking the Access Point

Make sure that you have the following items, which are included with the access point:

- Two external 2.4 GHz and 5.3 GHz dual-band antennas
- Mounting bracket (attached to the access point)
- Wall-mounting hardware:
 - Locking bar (used for securing a wall- or ceiling-mounted installation)
 - Two sheet metal screws
 - Two thread screws
 - Two wall anchors
- Four adhesive rubber feet (used for a flat-surface installation).

2 Preparing for Installation

It is advisable to connect the power (if using an external power supply) and check the Ethernet cables and LEDs before installing the access point in a hard-to-reach location. Additionally, observe the following items before mounting or connecting the access point:

| Installation Item | Description |
|--------------------|---|
| Switch port | 3Com recommends that you install and configure the 3Com Wireless LAN switch before installing the access point. Set the port type on the switch to an AP2750 access point. |
| Cabling | Make sure that standard Category 5 cable with straight-through signaling is installed at the site before you install the access point. Make sure that the cable is highly flexible and that there is no extra covering on the RJ-45 connector that could prevent the cable from being routed through the mounting bracket. |
| Power Requirements | Power can be supplied via an 802.3af Power Over Ethernet (PoE)-compliant device or by an external power supply with a minimum 5v @ 2.0 amp. If using an external power supply, make sure the power outlet is accessible. The power supply plug is the only means of disconnecting the access point from power. |
| MAC Address | Record the access point MAC address in a safe place before the access point is installed in a hard-to-reach location. The MAC address is printed on the back of the access point. Additional MAC address labels are shipped with the access point. |

3 Attaching the Antennas

Carefully unpack the standard detachable antennas. Screw the antennas on to the antenna connectors on the access point and hand-tighten them. After network startup, you may need to adjust the antennas to fine-tune coverage in your area.

For best results, adjust the antennas so that they are perpendicular with the floor and ceiling.



CAUTION: Do not handle the antenna tips, especially after they are connected to the access point. This could lead to electrostatic discharge (ESD), which could damage the equipment.

Connecting External Antennas

The access point has connectors for attaching optional external antennas and antenna cables. The tables below list the external antenna and cable models that are certified for use with the access point.

| Antenna Model | Type |
|---------------|--|
| 3CWE591 | 3Com 6/8 dBi Dual-Band Omnidirectional Antenna |
| 3CWE592 | 3Com 3/4 dBi Dual Band Ceiling Antenna |
| 3CWE597 | 3Com 6/8 dBi Dual-Band Hallway Antenna |

| Cable Model | Type |
|-------------|---|
| 3CWE580 | 3Com Ultra Low Loss 6-Foot Antenna Cable |
| 3CWE581 | 3Com Ultra Low Loss 20-Foot Antenna Cable |
| 3CWE582 | 3Com Ultra Low Loss 50-Foot Antenna Cable |

The 3Com antennas are dual-band, which means that they operate in both 2.4GHz and 5GHz spectra. You can use these antennas with either the 802.11b/g radio or the 802.11a radio.

Each antenna requires the purchase of a separate antenna cable.



NOTE: Antenna cables introduce loss of the RF signal. Always use the shortest cable that your application allows.

For installation instructions, see the documentation that is supplied with the antenna.



NOTE: During the installation, connect the antenna to the access point before connecting the Category 5 Ethernet cable. This ensures that the access point is not powered on when the access point is connected to the network.

4 Mounting the Access Point

The access point can be mounted on the following types of surfaces:

- Wall, ceiling, or electrical box (NEMA enclosure)
- Tabletop



CAUTION: The access point is intended for indoor use only. Do not install the access point outdoors unless you install it in a properly installed outdoor access point enclosure.

Wall, Ceiling, or Electrical Box Mounting

To mount the access point to a wall, ceiling, or electrical box:

- 1 Remove the access point from the mounting bracket.**
- 2 Screw the mounting bracket to a wall, ceiling, or electrical box (NEMA enclosure):**
 - If mounting to a solid surface wall or ceiling, use the two sheet metal screws.
 - If mounting to drywall, use the two sheet metal screws and two wall anchors.
 - If mounting to an electrical box (NEMA enclosure), use the two threaded screws.
- 3 Route the power cable (if using an external power supply) and Ethernet cable through the large opening on the back of the mounting bracket.**



CAUTION: For easy installation and removal of the access point from the mounting bracket, make sure that there is sufficient flexibility with the cable and that there is adequate service loop (that is, enough cable routed through the mounting bracket to easily connect the cable to the access point.) If not enough cable is routed through the back of the mounting bracket, or if the cable is inflexible, it can be difficult to install or remove the access point from the mounting bracket.

The figures below show the mounting bracket being mounted to a wall, and then a cable being routed through the large opening on the back of the mounting bracket.

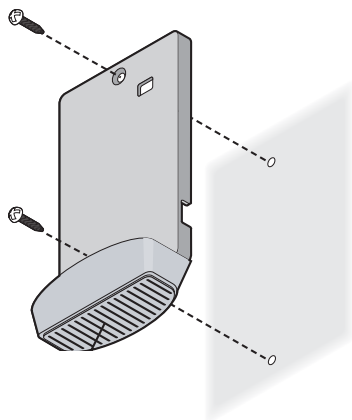

Installing the mounting bracket

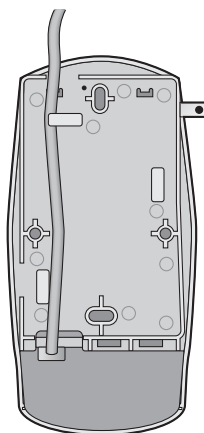

Routing a cable

- 4 Connect the Ethernet cable (and power cable, if applicable) to the port(s) on the front of the access point.**
- 5 Snap the access point onto the mounting bracket.**

To install the locking bar, push the locking bar through the opening in the side of the mounting bracket until the hole on the locking bar is exposed. Insert a lock (not provided) through the hole on the locking bar, and then close the lock to secure it in place.

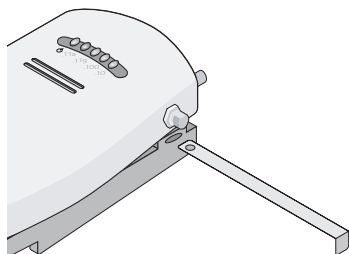

Inserting the locking bar

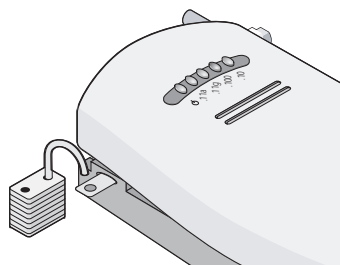

Securing the bar with a lock

Tabletop Mounting

To install the access point on a flat surface such as a table or desktop:



CAUTION: Do not place the access point on any type of metal surface. Select a location that is clear of obstructions and provides good reception.

- 1 Remove the backing from the four rubber feet and attach them on the bottom of the mounting bracket that is attached to the access point.**
- 2 Place the access point on the table.**
- 3 Connect the Ethernet cable (and power cable, if applicable) to the port(s) on the front of the access point.**

5 Connecting the Access Point to a Switch

3Com recommends that you install and configure the 3Com Wireless LAN switch before installing the access point. If the switch is already installed and configured for the access point, you can immediately verify the cable connection when you plug the cable into the access point.



WARNING: Do not connect or disconnect cables or otherwise work with the access point during periods of lightning activity.

You can connect the access point directly to a 3Com Wireless LAN Switch port or indirectly to 3Com Wireless LAN switches through an intermediate Layer 2 or Layer 3 network. In either case, use Category 5 cable with straight-through signaling for each access point connection.

- To connect the access point directly to a 3Com Wireless LAN Switch, configure the switch port as an AP2750 access point and then insert the cable into the switch and verify the link.
- To connect the access point indirectly to a 3Com Wireless LAN Switch through the network, configure a Distributed Access Point connection on the switch.



Note: For instructions on configuring the access point, see the *Mobility System Configuration Guide* or the *3Com Wireless LAN Switch Reference Manual*.

6 Checking the LED Indicators

When the access point is connected to power, LEDs indicate activity as follows (solid LED indicates connection; blinking LED indicates activity):

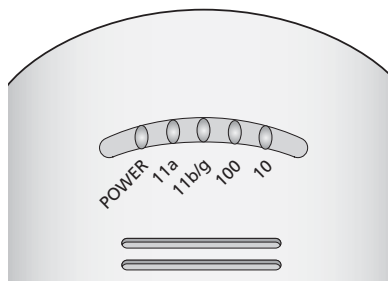

| LED | Color | Indicates |
|-------|-------|---|
| Power | Green | The access point is powered up and operating normally. |
| | Off | The access point is not receiving power or there is a fault with the power supply. |
| 11a | Green | The access point has WLAN frame transmission over the 802.11a 5.3 GHz radio band. |
| | Off | No link is present. |
| 11b/g | Green | The access point has WLAN frame transmission over the 802.11b/g 2.4 GHz radio band. |
| | Off | No link is present. |
| 100 | Green | The access point has a 100 Mbps Fast Ethernet connection. |
| | Off | No link is present. |
| 10 | Green | The access point has a 10 Mbps Ethernet connection. |
| | Off | No link is present. |

Troubleshooting

Refer to the *Mobility System Configuration Guide* or to the *3Com Wireless LAN Switch Reference Manual* to obtain the access point status.

Copyright © 2006 3Com Corporation. All rights reserved. 3Com and the 3Com logo are registered trademarks of 3Com Corporation. All other company and product names may be trademarks of the respective companies with which they are associated.

Part Number 10015413 Rev. AA
Published July 2006